

VFXO110

XO

9x14mm SMD, LVPECL



Features

- 19MHz to 200MHz Frequency Range
- Ultra Low Jitter and Phase Noise
- Low Aging, Vacuum Sealed Crystal

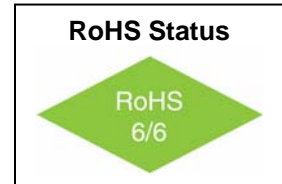

Applications

- Optical Networking, SONET / SDH
- 10 Gigabit Ethernet
- Broadband Access

Replaces Valpey Fisher Part Number(s): VFT561

Electrical Specifications

Parameter	Symbol	Condition	Min	Typ	Max	Unit	Note
Frequency Range	F		19		200	MHz	
Frequency Stability	$\Delta F/F$	Vs. Operating Temperature B: 0°C to +70°C G: -40°C to +85°C			± 20 ± 20	ppm	
		Vs. Supply Voltage Vs. Aging / Year		± 3 ± 1		ppm/V ppm	First Year
Operating Temperature Range	T		0° -40°		+70° +85°	°C	Order Code B Order Code G
Output		Signal	LVPECL Unterminated				
Phase Jitter		1 σ		0.2	0.5	ps	
SSB Phase Noise		100Hz		-95		dBc/Hz	@ 155.52MHz
		1KHz		-125			
		10KHz		-140			
		100KHz		-145			
Supply Voltage	Vcc		3.15	3.30	3.45	V	
Input Current	Icc	50 Ohm Load			75	mA	



VFXO110
XO
9x14mm SMD, LVPECL



Electrical Specifications

Parameter	Symbol	Condition	Min	Typ	Max	Unit	Note
Load	50 Ohm to Vcc-2V or Thevenin Equivalent Bias Required						
Duty Cycle		@ 50%	45	50	55	%	
Rise / Fall Time	Tr/Tf	20% to 80%			0.5	ns	
Logic "1" Level	Voh		Vcc-0.96		Vcc-0.81	V	
Logic "0" Level	Vol		Vcc-1.85		Vcc-1.65	V	
Start up time				2	10	ms	
Subharmonics				-50	-40	dBc	
Enable / Disable Function	Input HIGH (>2.5V): DISABLED Input LOW (<0.5V) or floating: ACTIVE						
Enable / Disable Time	Te/Td				100	ns	

How to Order

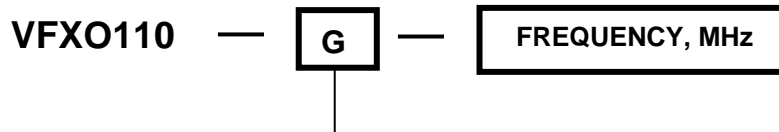

Temperature Range

Code	Specification
B	0°C to 70°C
G	-40°C to 85°C



VFX0110 XO 9x14mm SMD, LVPECL



Absolute Maximum Ratings

Parameter	Symbol	Condition	Min	Typ	Max	Unit	Note
Supply Break Down Voltage	V _{cc}		-0.5		7.0	V	
Storage Temperature	T _s		-55		+85°	°C	

Environmental and Mechanical

Parameter	Specification
Mechanical Shock	Per MIL-STD-202, Method 213, Condition E
Thermal Shock	Per MIL-STD-883, Method 1011, Condition A
Vibration	Per MIL-STD-883, Method 2007, Condition A
Soldering Conditions	260°C for 10s max
Hermetic Seal	Leak rate less than 5x10 ⁻⁸ atm.cc/s of helium (crystal only)

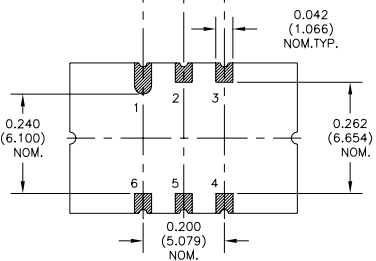
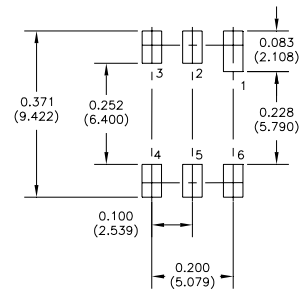
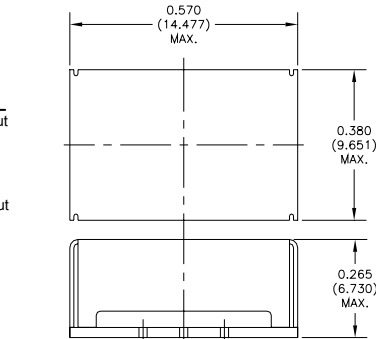
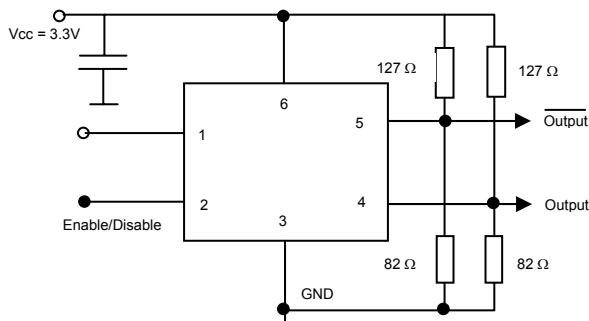

Pin #	Connection
1	NC
2	Enable
3	Case, GND
4	Output
5	Output
6	V _{cc}

